



ST-26 Mini Spider

INDUSTRIAL PRODUCT OFFERINGS



The ST-26 is the product of choice for work in stacks, ship holds, boilers, digesters, power plants and similar areas with limited access, where a trailing wire rope can be a hazard.

- Has the capacity to carry two people
- Air-powered motor
- Reliable vented transmission prohibits entry of corrosive agents for greater durability.
- Reinforced midair transfer point
- Passes through an 18 in. (457 mm) circular opening
- Also available in larger dimensions with an electric motor by special order

Specifications: ST-26
Gross Load Capacity: 1,000 lbs. (453.6 kg)
Dimensions: Open: 57 x 17 1/2 x 76 in. (1,448 x 445 x 1,930 mm) Folded: 13 1/2 x 17 1/2 x 76 in. (343 x 445 x 1,930 mm)
Weight: 180 lbs. (81.7 kg)
Travel Speed: 30 ft/min (9.2 m/min)
Power Requirements: 120 psi air @ 60 cfm
Drum Capacity: 235 ft (72 m)
Wire Rope Size and Construction: 5/16 in. (8 mm) Seale Construction 6 x 19
Construction: Aluminum and steel

For welding installation details, see pages 197-198.



ST-26 attached to platforms

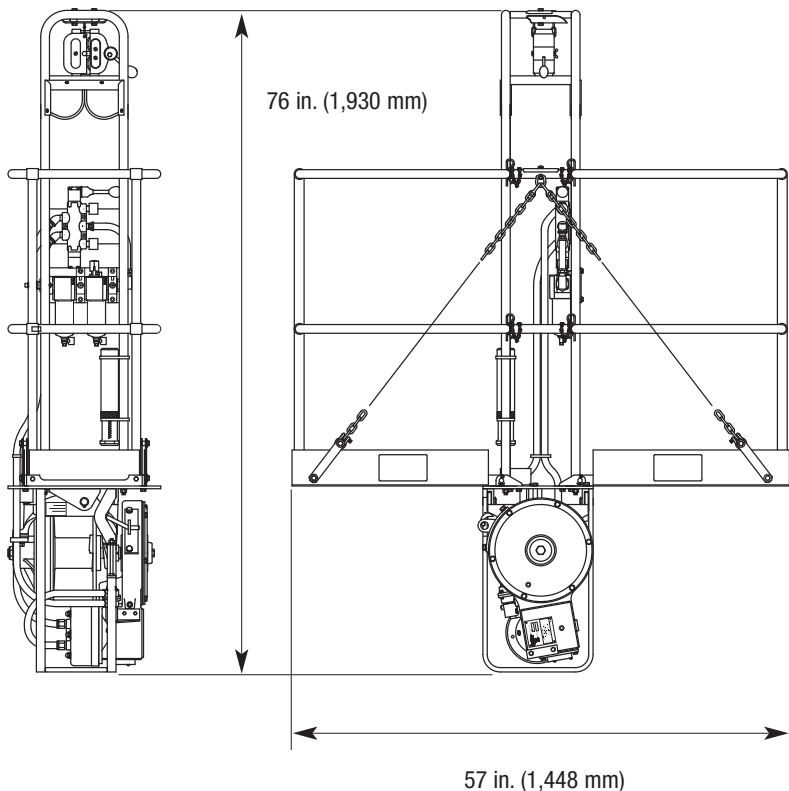
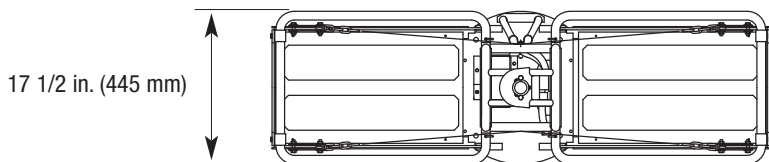

Frequently used accessories:

- SA-1002 Transfer Chain on page 222.
- SA-1083-26 Drum Hoist Arc Guard Kit on page 224.
- 702049 Whip on page 183.

More information online at
www.spiderstaging.com

For more information, call: 1-877-774-3370