

Tank Top Roller–Pin Style (700525-1)

**Steel roller with shackle for tieback and suspended load;
Effective for rigid top petroleum and other storage tanks**

Key Features:

- Heavy duty steel construction
- Fully sealed bearing allows both shackles to pivot freely
- Pivoting shackles aid easy rolling
- Capped ends prevent entry of debris into shaft to prolong device life
- Sealed bearing makes rolling smooth and easy
- Sealed bearing does not require lubrication
- Designed for corrosive environments
- Extensive product labels make installation goof-proof
- Built by Spider in the USA

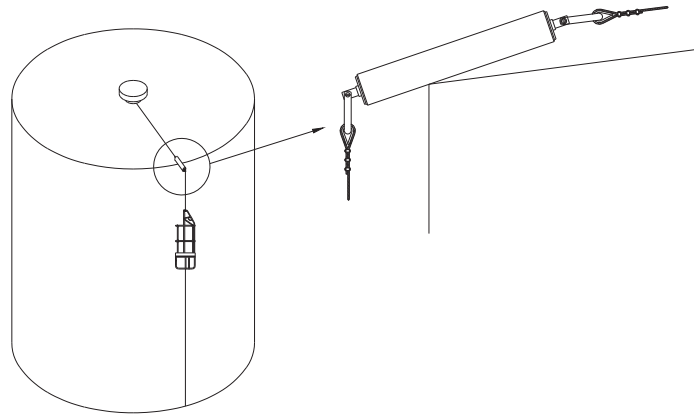

Specifications:	700525-1
Load/Capacity:	Maximum 1,500 lbs. (680.4 kg)
Dimensions:	41 in. (1,041 mm) long x 4 in. (102 mm) o.d.
Weight:	46 lbs. (20.9 kg)
Outreach:	12 in. (304 mm) from edge of tank
Construction:	Steel

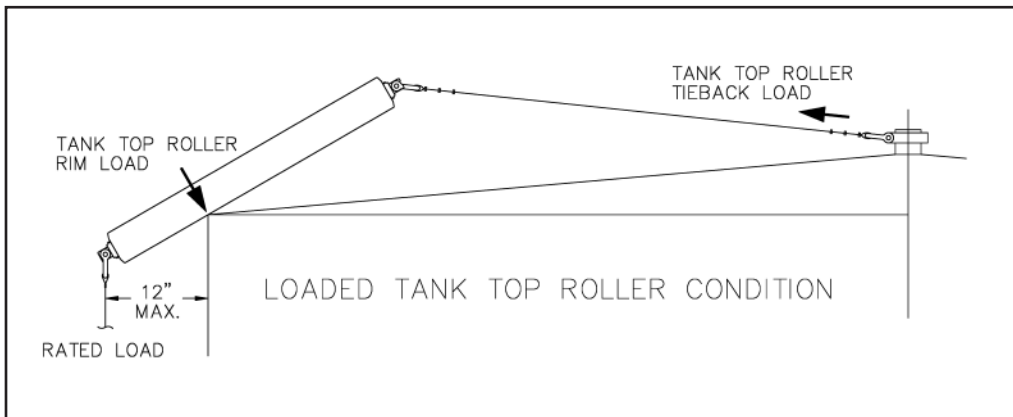
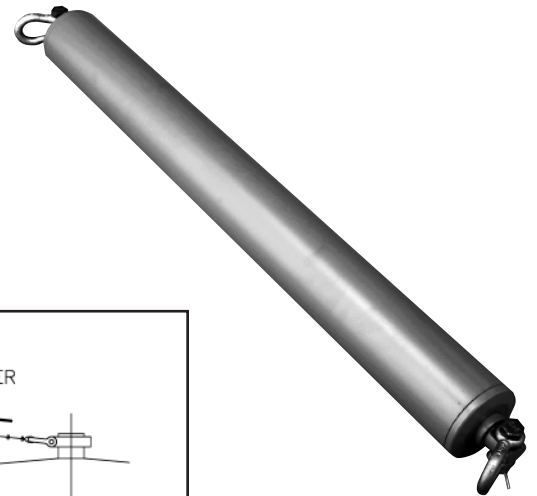

**Protect your investment!
Use hoist covers on page 139.**