

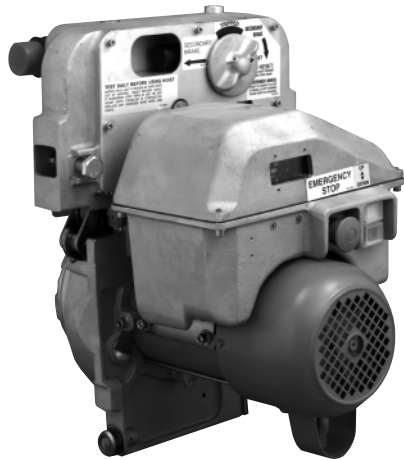

# SC40 Spider Climber



The SC40 is Spider's original electric traction hoist and is known for its proven reliability in rental fleets.

Modular construction allows for quick assembly and easy use, inspection and maintenance (with 2 bolt disassembly).

Spider equipment has been used by various contractors and subcontractors including caulkers, glazers, inspectors, iron workers, marine contractors, masons, painters and waterproofers, and has consistently exceeded their expectations.

The typical assembly of this hoist model is on a modular platform, a work cage and as a material hoist.

### Key features:

- Electromagnetic primary brake
- Built-in secondary overspeed brake
- Emergency stop button
- Full power cut-off switch
- Overload sensor
- Hour meter
- Power indicator light
- Tolerant light touch reeving system
- Controlled descent at half rated speed during power loss
- **Available in rental fleet only**

*Can be combined with a variety of stirrups and platforms*

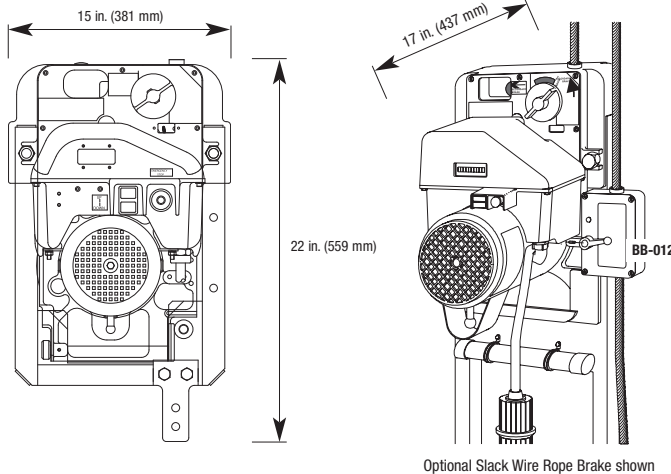

Optional Slack Wire Rope Brake shown

Specifications:	SC40
Gross Load Capacity:	1,000 or 1,500 lbs. (453.6 or 680.4 kg)
Dimensions:	15 x 17 x 22 in. (381 x 437 x 559 mm)
Weight:	Various (see Hoist Comparison Table on page 35)
Travel Speed:	35 ft/min (10.7 m/min)
Voltage Options:	220V single phase, 208V three phase
Wire Rope Diameter:	5/16 in. (8 mm)
Construction:	Aluminum and steel

1,500 lb. (680.4 kg) model available

- 99115: Single phase
- 99135: Three phase



**For more information, call: 1-877-774-3370**